

DATE	ISSUE

STEEFORM RENTAL, LLC
 312 West Simonds Road
 Seagoville, TX 75159
 PHONE 972 287-4290 FAX 972 287-2651

PROJECT:
 LOCATION:
 ARCHITECT:
 CONTRACTOR:

CONTRACT NUMBER
 DRAWN BY
 DATE
 11/29/04
 DRAWING SCALE
 SHEET TITLE
 Typical Steelform
 SHEET NUMBER

DEPTHS	WIDTHS
8"	10', 15', 20' & 30'
10"	10', 15', 20' & 30'
12"	10', 15', 20' & 30'
14"	10', 15', 20', 30', 40', 53' & 66'
16"	10', 15', 20', 30', 40', 53' & 66'
18"	10', 15', 20' & 30'
20"	10', 15', 20', 30', 40', 53' & 66'
24"	10', 15', 20', 30', 40', 53' & 66'

** AVAILABLE QUANTITIES MAY VARY BY SIZE**

- GENERAL INSTALLATION NOTES
1. 20" AND 24" DEEP FORMS REQUIRE:
 2 DIAPHRAGMS PER 4' LONG PAN
 1 DIAPHRAGM PER 3' LONG PAN
 - 16" DEEP FORMS REQUIRE :
 1 DIAPHRAGM PER 4' LONG PAN
 1 DIAPHRAGM PER 3' LONG PAN
 2. NAIL ALL NAIL HOLES IN ENDCAPS AND FORMS.
 3. ALL FORMS ARE 14 GAGE MINIMUM.
 4. ALL FORMS HAVE 1" SIDE SLOPE.
 5. TOP OF FORMS ARE SELF SUPPORTING AS FOLLOWS:
 66" WIDE - 5"; 53" WIDE - 7"; 30" WIDE - 7";
 20" WIDE - 7"; 15" WIDE - 7"; 10" WIDE - 7".

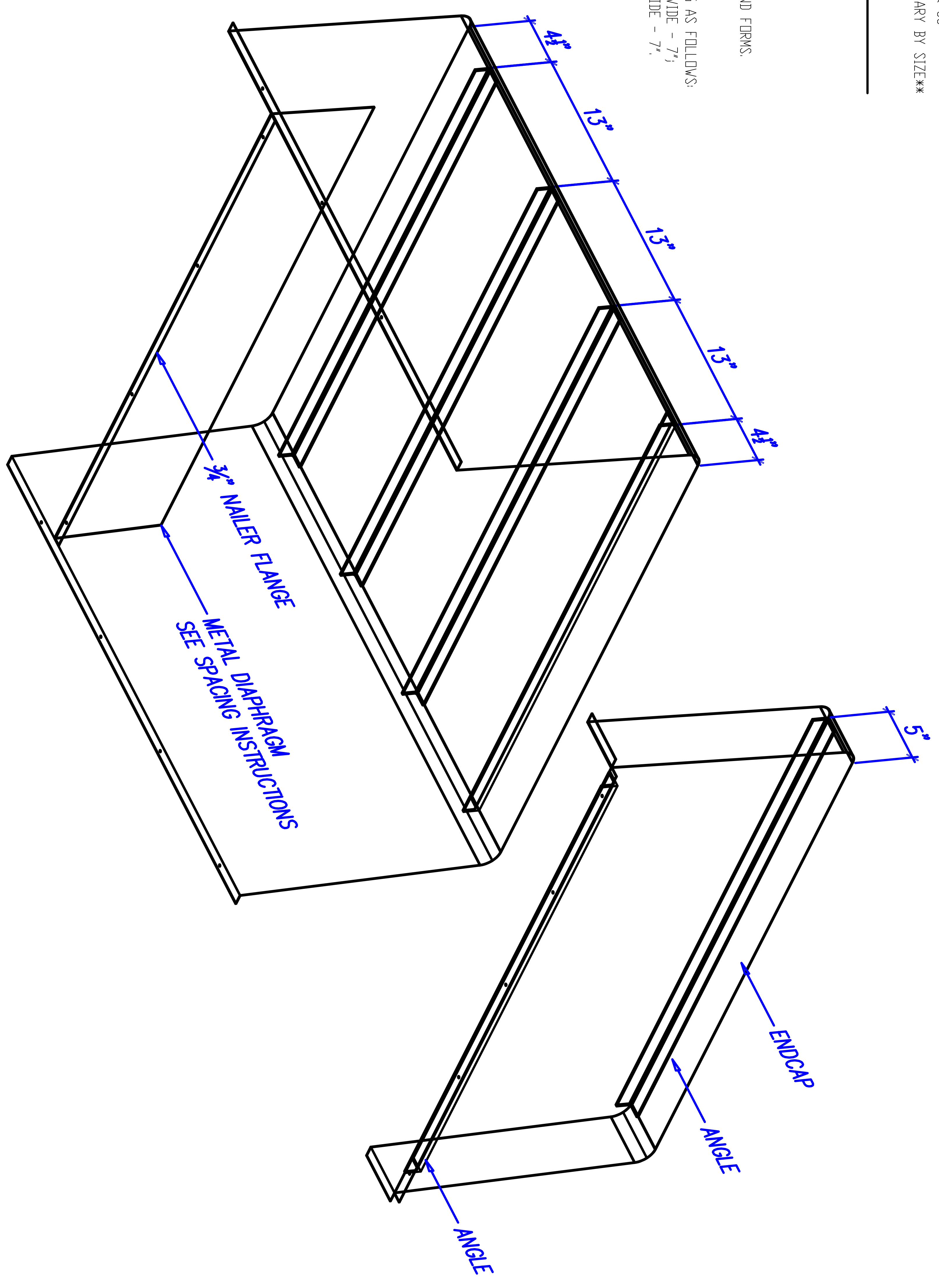

*****NOTE: THIS SKETCH IS FOR GENERAL INFORMATION ONLY, NOT TO SCALE*****